

**KNAPHEIDE**  
SINCE 1848



GENERAL MOTORS  
**ALUMINUM KUV BODIES**

# KNAPHEIDE ALUMINUM KUV BODIES



## ALUMINUM Knapheide UTILITY VAN

Working out of a Knapheide KUV keeps you organized and productive. Large perimeter bins are easy to access and keep your parts and tools separated into easy-to-manage spaces.

A spacious cargo storage area with interlocking aluminum extrusion floor for transporting drywall, larger tools, water heater, and oversized items.

## ALUMINUM KUV BODIES

The Knapheide Aluminum KUV is available in multiple heights and lengths for different applications. It is designed to increase productivity and efficiency through better organization of parts and equipment for specialty contractors, including plumbers, HVACR technicians, electricians, and more.

No more looking for what you need — just grab and go!

## POPULAR VOCATIONS



CONSTRUCTION



PLUMBING

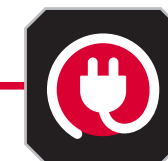

ELECTRICAL

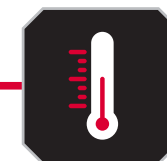

HVACR

**A. BODY HAS AN AEROSPACE DESIGN AND ASSEMBLY**

for unmatched durability. Composed of military grade aluminum extrusions

**B. GALVA-GRIP BUMPER WITH KNAPLINER**

for increased grip, durability, and corrosion resistance

**C. INTEGRATED LED S/T/T AND B/U, LED STROBE OPTION\***

with (8) selectable patterns and built-in reflectivity for additional safety\*\*  
 \*Additional wire harness required for strobe lights  
 \*\*Covered under 3-year limited warranty

**D. TWO REAR LOCKABLE CONDUIT CHUTES**

providing quick access for longer items

**E. SOLID REAR DOORS ARE STANDARD**

providing increased security. Underlap rear door features an interior release handle that is ergonomically friendly Knapheide (or OEM) white paint on exterior, compartment interiors, and cargo area of service body

**F. AUTOMOTIVE-QUALITY, PADDLE-ACTIVATED ROTARY STYLE LATCHES**

make opening and closing easy, providing access to spacious side compartments

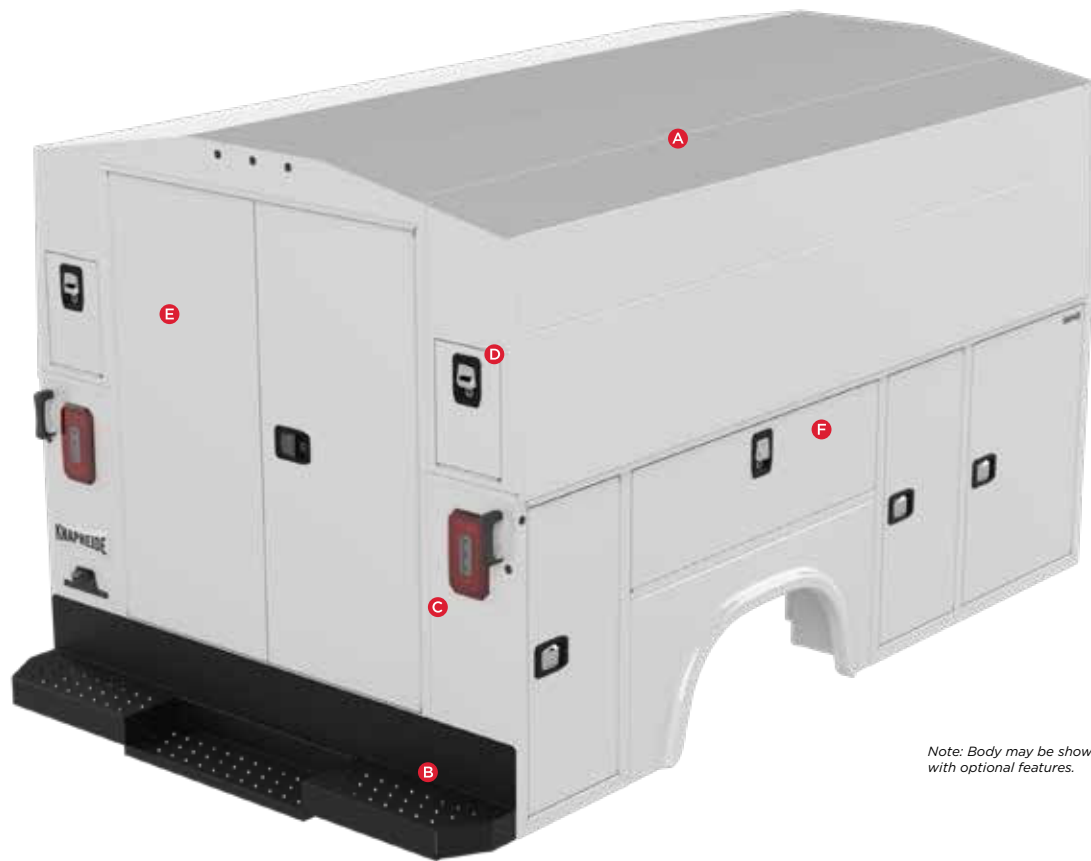

*Note: Body may be shown with optional features.*

FEATURES NOT SHOWN

**COMPARTMENTS CAN BE LOCKED INDEPENDENTLY**  
for maximum security

**INTERIOR LED DOME LIGHT**  
in cargo area with light switch inside the cargo doors

**REFINED ABS PARTITION**  
is equipped with a sliding cab access door and window. The door's slam latch can be locked from the cab and secured in either an open or closed position

**GRAB HANDLE**  
(rear right)



**CARGO AREA AND CONDUIT CHUTE CAPACITY**

10' in 129" bodies



**AERODYNAMIC WIND DEFLECTOR**

Mounted on body above cab  
(Standard on DH and SH models only)

COMPARTMENT FEATURES



**MASTER LOCKING SYSTEM**  
for piece of mind — locks down all of the side compartments in one move



**NITROGEN STRUT DOOR RETAINERS**  
on vertical compartment doors eliminate involuntary swing



**INSET DOOR FRAME DESIGN WITH DOUBLE TRAY ALUMINUM DOORS AND NEOPRENE SEALS**  
for weather-tight closing



**CONTINUOUS ALUMINUM HINGE WITH STAINLESS STEEL RODS**  
are pry-proof and corrosion-resistant

STANDARD SHELVING



**STREET AND CURB SIDE FRONT VERTICAL COMPARTMENTS**  
Two adjustable divider shelves and dividers, with a 250-lb. capacity



**STREET AND CURB SIDE FULL HEIGHT REAR VERTICAL COMPARTMENTS**  
One adjustable divider shelf and dividers, with a 250-lb. capacity



**CURB SIDE HORIZONTAL COMPARTMENT**  
One adjustable divider shelf and dividers, with a 250-lb. capacity

REQUEST A QUOTE



Visit [knapheide.com/quote](https://knapheide.com/quote) and fill out the form to receive a quote and additional product information.



## POPULAR OPTIONS



**POWER LOCKS**



**CODEABLE PADLOCK**



**UPPER SIDE GLASS**

*Available for Low and High Roof models. Not available for Ultra-Low models.*



**POWER LIFTGATE**

*Not available on SRW models*



**LED COMPARTMENT LIGHTING**



**REAR VISION CAMERA**



**ALUMINUM DRAWERS**



**PULL OUT TRAY**



**3 BOW LADDER RACK**



**SIDE ACCESS DOOR**

*Available for Low and High Roof models. Not available for Ultra-Low models.*



**CLASS V RECEIVER HITCH**



**E-TRACK**



**SIDE MOUNT LADDER RACK**

# MODEL OPTIONS

## ALUMINUM KUV BODIES

CHASSIS MODEL	CA	WHEELBASE	CHASSIS WEIGHT <sup>1</sup>	BODY MODEL	BULK CARGO AREA	TOTAL STORAGE	COMPARTMENT AREA	BODY HEIGHT	BODY WEIGHT	CHASSIS GVWR	PAYLOAD <sup>2</sup>
G33503	80"	139"	4,718 lb.	AKUV129SU	231 cu. ft.	292 cu. ft.	61 cu. ft.	68"	1,160 lb.	9,900 lb.	4,022 lb.
G33503	80"	139"	4,718 lb.	AKUV129SL	293 cu. ft.	354 cu. ft.	61 cu. ft.	78"	1,266 lb.	9,900 lb.	3,916 lb.
G33503	80"	139"	4,718 lb.	AKUV129SH	360 cu. ft.	421 cu. ft.	61 cu. ft.	90"	1,327 lb.	9,900 lb.	3,855 lb.
G33503	80"	139"	5,225 lb.	AKUV129D20L	313 cu. ft.	401 cu. ft.	88 cu. ft.	78"	1,324 lb.	11,500 lb.	4,951 lb.
G33503	80"	139"	5,225 lb.	AKUV129D20H	384 cu. ft.	472 cu. ft.	88 cu. ft.	90"	1,383 lb.	11,500 lb.	4,892 lb.

<sup>1</sup> Chassis weight calculated with 6.6L gas engine. Optional engines and other chassis may affect chassis weight.

<sup>2</sup> Final payload calculation subject to chassis and body options.

\*\*"S" model denotes single rear wheel with 14.5" deep compartments.

\*\*\*"D" model denotes dual rear wheel with 14.5" deep compartments.

\*\*\*"D20" model denotes dual rear wheel with 20" deep compartments.



### AKUV129SU / AKUV129SL

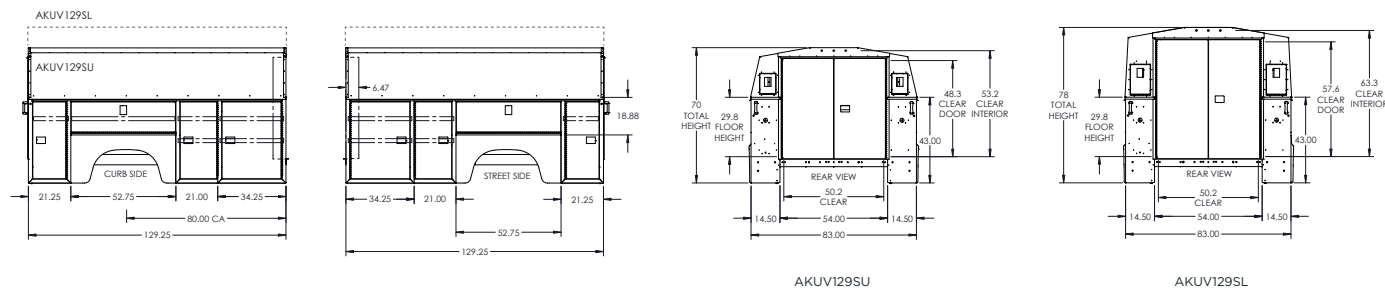

### AKUV129D20L / AKUV129D20H

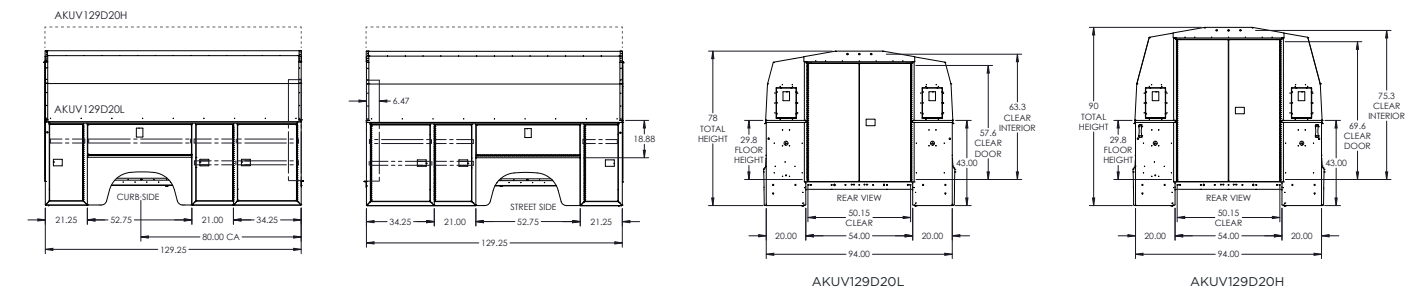

### AKUV129SH

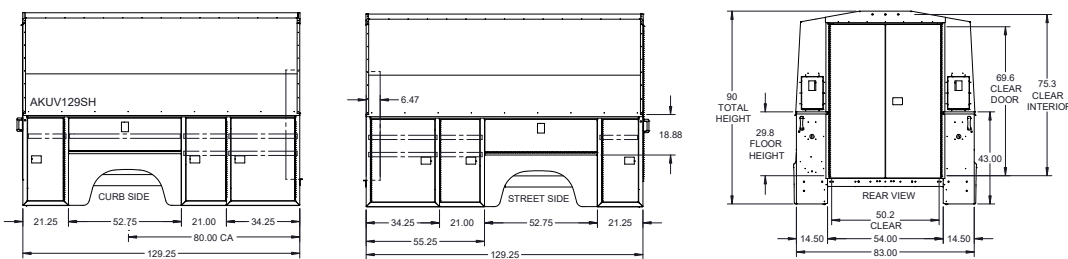

# COMMITMENT TO CORROSION RESISTANCE

Aluminum bodies are naturally corrosion resistant. Where steel fasteners are used, those fasteners are coated with "EcoGuard" to eliminate the interaction between the steel and aluminum.

This aluminum assembly method allows us to create products with the highest level of corrosion resistance available.



FOLLOW US  
LIKE US  
TAG US



## TEN YEAR, LIMITED TIME WARRANTY



**NO RUST  
THROUGH**



**DOOR HINGES  
WILL NOT FAIL OR  
COME OFF BODY**



**LATCHES AND LOCK  
CYLINDERS WILL NOT  
FAIL TO OPERATE**



**SHELVES WILL NOT  
BEND UNDER MAX.  
LOAD OF 250 LBS.**

TO LEARN MORE VISIT  
[www.knapheide.com/warranty](http://www.knapheide.com/warranty)



# NEVER SETTLE

If you are going to be a leader, it takes more than building a high-quality product. It means never being totally satisfied with that product, no matter how high quality it may be. It requires constant vigilance and a willingness to take a chance on something new. And it means exceeding expectations every time. As the industry changes, one thing never will—our commitment to making customers like you as productive and efficient as possible. We know you don't settle, and we don't either. That's why we want you never to settle for anything less than Knapheide on the back of your truck.

**KNAPHEIDE. NEVER SETTLE.**



The Knapheide Manufacturing Company  
1848 Westphalia Strasse | Quincy, IL 62305  
217-222-7131  
[www.knapheide.com](http://www.knapheide.com)