

**KNAPHEIDE**  
SINCE 1848



**LINE BODIES**

# KNAPHEIDE LINE BODIES



## AVAILABLE STYLES



## CONVENTIONAL

Conventional style line bodies include compartments behind the rear wheels. Standard models are available in body lengths from 10' to 14'.

They are compatible with aerial and non-aerial applications, as well as a canopy roof.



## BOBTAIL

Bobtail style line bodies do not include compartments behind the rear wheels. Standard models are available in both 11' and 12' lengths.

They are compatible with digger derrick, aerial and non-aerial applications.

## POPULAR VOCATIONS



**POWER  
GENERATION**

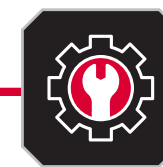

**MUNICIPALITIES/  
UTILITIES**



**CONSTRUCTION**

## LINE BODIES

Knapheide Line Bodies are engineered to handle some of the most demanding applications out there. Compatible with medium-duty or heavy-duty chassis, Knapheide Line Bodies have been put to the test in many different industries including utility, municipality, power generation, construction and more.

With a variety of options to fit any need, the Knapheide Line Body can be configured to best suit your job.

# PRODUCT FEATURES

## A. BODY SHELL

Rugged 14-gauge, two-sided A-40 galvanized steel construction for durability and corrosion resistance

## B. CONTINUOUS STAINLESS STEEL HINGES

are pry-proof and corrosion-resistant

## C. AUTOMOTIVE-QUALITY, PADDLE-ACTIVATED ROTARY STYLE LATCHES

make opening and closing easy

## D. EXCLUSIVE "RETURN FLANGE" FLOOR DESIGN

provides support for side compartments, adds floor strength, and eliminates rust-prone exposed seam between floor and side compartments

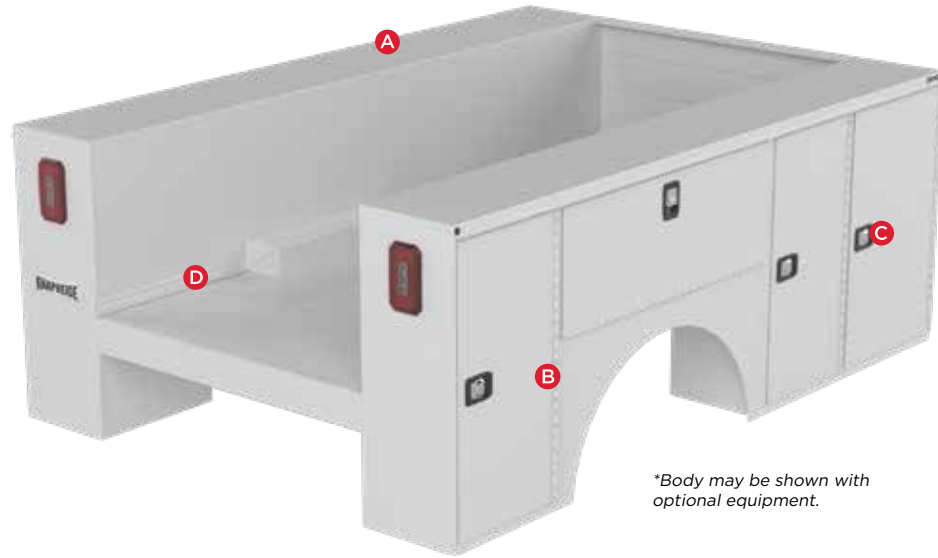

\*Body may be shown with optional equipment.



REQUEST A QUOTE



Visit [knapheide.com/quote](https://knapheide.com/quote) and fill out the form to receive a quote and additional product information.

## FEATURES NOT SHOWN

**ELECTRODEPOSITION PRIME-PAINT SYSTEM**  
provides superior corrosion resistance

**DOUBLE-SPRING OVER-CENTER RETAINER**  
on vertical compartment doors eliminate involuntary swing

**C-CHANNEL UNDERSTRUCTURE**  
superior understructure strength from 6" formed C-Channel cross sills

**NEOPRENE DOOR SEALS**  
protect compartments from the weather

## MODEL OPTIONS

### CONVENTIONAL MODELS

MODEL	CHASSIS CA	BODY LENGTH	BODY HEIGHT	BODY WIDTH	FLOOR WIDTH	COMPARTMENT DEPTH	WEIGHT
6121H	72"	121.25"	50"	94"	58"	18"	1,777 lb.
6133H	84"	133.25"	50"	94"	58"	18"	1,894 lb.
6147H	102"	147.25"	50"	94"	58"	18"	2,126 lb.
6155H	108"	155.25"	50"	94"	58"	18"	2,233 lb.
6165H	120"	165.25"	50"	94"	58"	18"	2,332 lb.
6169H	124"	169.25"	50"	94"	58"	18"	2,377 lb.

### BOBTAIL MODELS

(excludes rear compartments: for use with aerial buckets and digger derricks)

MODEL	CHASSIS CA	BODY LENGTH	BODY HEIGHT	BODY WIDTH	FLOOR WIDTH	COMPARTMENT DEPTH	WEIGHT
6133BH	108"	133.25"	50"	94"	58"	18"	1,895 lb.
6145BH	120"	145.25"	50"	94"	58"	18"	2,014 lb.

## POPULAR OPTIONS



**PULL-OUT TRAY**



**BOTTLE GAS RETAINER**



**MASTER LOCKS**



**CABLE STEPS**



**CARGO TIE DOWNS**



**SWIVEL HOOKS**



**GRAB HANDLES**



**OUTRIGGER PAD CARRIERS**



**LED COMPARTMENT LIGHTING**



**SIDE ACCESS STEPS**



**RUBBER FENDERETTES**



**SHELVING AND DIVIDERS**



**TAILBOARD CHANNEL**



**ALUMINUM MECHANICS DRAWERS**



**REAR ACCESS DOOR AND FULL LENGTH SHELF**

# COMMITMENT TO CORROSION RESISTANCE

Corrosion won't be a concern when you buy quality Knapheide products. To give you the best corrosion protection, we utilize a state-of-the-art, custom-designed, 12-step, SST cathodic electrodeposition finishing system, called "E-Coat."

It bonds prime paint to steel by an electroplating process to give you a superior coat of primer, resulting in better corrosion protection compared to spraying methods.

This system allows us to create products with the highest level of corrosion resistance available.



FOLLOW US  
LIKE US  
TAG US



## SIX YEAR, LIMITED TIME WARRANTY



**NO RUST  
THROUGH**



**DOOR HINGES  
WILL NOT FAIL OR  
COME OFF BODY**



**LATCHES AND LOCK  
CYLINDERS WILL NOT  
FAIL TO OPERATE**



**SHELVES WILL NOT  
BEND UNDER MAX.  
LOAD OF 250 LBS.**

TO LEARN MORE VISIT  
[www.knapheide.com/warranty](http://www.knapheide.com/warranty)



# NEVER SETTLE

If you are going to be a leader, it takes more than building a high-quality product. It means never being totally satisfied with that product, no matter how high quality it may be. It requires constant vigilance and a willingness to take a chance on something new. And it means exceeding expectations every time. As the industry changes, one thing never will—our commitment to making customers like you as productive and efficient as possible. We know you don't settle, and we don't either. That's why we want you never to settle for anything less than Knapheide on the back of your truck.

**KNAPHEIDE. NEVER SETTLE.**



The Knapheide Manufacturing Company  
1848 Westphalia Strasse | Quincy, IL 62305  
217-222-7131  
[www.knapheide.com](http://www.knapheide.com)