

KNAPHEIDE
SINCE 1848



GENERAL MOTORS
MECHANICS TRUCKS

KNAPHEIDE MECHANICS TRUCKS

Knapheide Mechanics Trucks come equipped with standard features to help you get the job done. With secure side compartments and an oversized cargo space, you can carry everything you need.

Choose a Knapheide Mechanics Truck for the durability and functionality that stands above the rest.

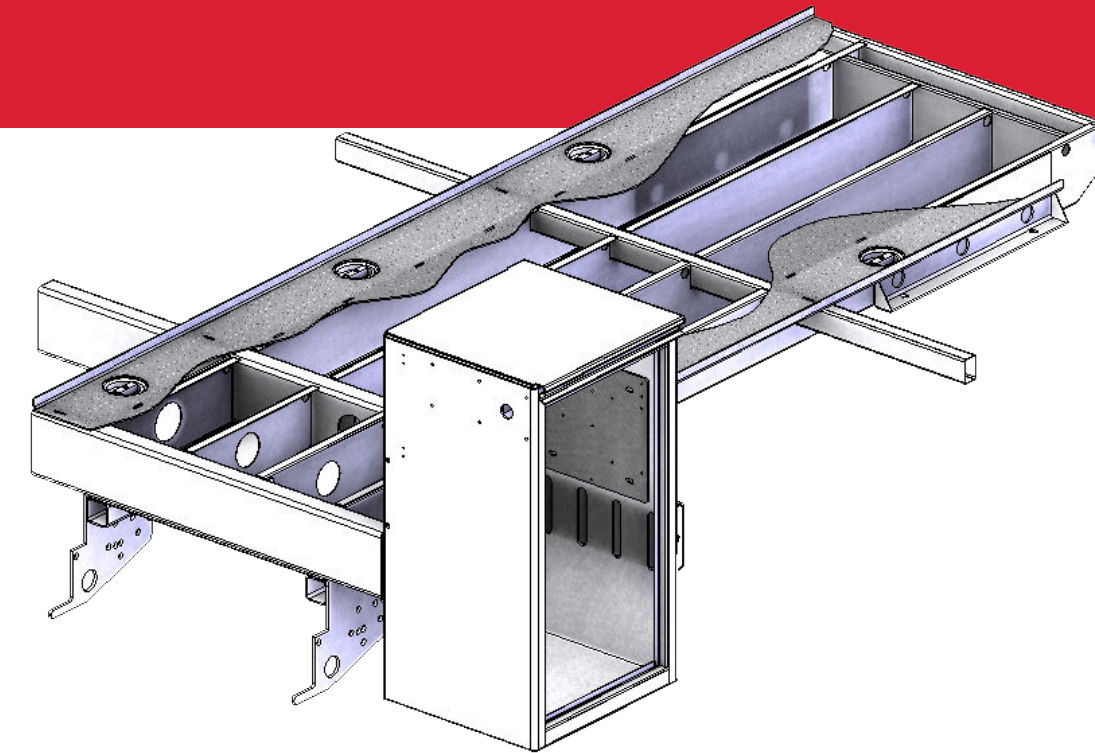

CRANE BODY UNDERSTRUCTURE

Unique torq-isolator crane support system transfers lift forces into the full length torsion box subframe and outriggers, and not the side compartments.

Reinforced rear vertical curb side compartment is independent of all other side compartments, eliminating flexing and twisting of side packs.

**Applies to all models with exception of the steel KMS16.*

AKMT1 & KMT1 MODELS

Knapheide AKMT1 and KMT1 Mechanic Trucks are purpose-built with heavy duty technicians and mechanics in mind. These bodies are built for crane load capacities of up to 8,600 lb. These are compatible with Class 5 and 6 trucks with 19.5 tires.

AKMS16, KMS16, AKMS30 & KMS30 MODELS

Knapheide AKMS16 and KMS16 trucks are equipped with an electric crane, while AKMS30 and KMS30 trucks have the option of either an electric or hydraulic crane for lifting applications. Both are compatible with Class 3-6 trucks with up to 19.5 tires.

POPULAR VOCATIONS



**HEAVY
CONSTRUCTION**



AGRICULTURE



**PREVENTATIVE
MAINTENANCE**



OIL/MINING/GAS

A. DOUBLE paneled doors
on steel models made of 20-gauge galvalume steel. Aluminum models feature box structure design of 5052 Aluminum

B. 3-POINT T-HANDLE LATCHES
ensure your compartment doors stay closed and are individually lockable

C. MASTER LOCKING SYSTEM
locks down all compartments on one side with one motion

D. Knapliner bumper
provides work surface with lockable through compartment, a vise plate, and two grip strut flex steps

E. HEAVY DUTY ALUMINUM GRAB HANDLES
installed on both sides at rear of the body for easy cargo area access

F. INTEGRATED LED S/T/T AND B/U, LED STROBES
with (8) selectable patterns and built-in reflectivity mounted to external rear light boxes made of UV-resistant ABS material

G. 16" HIGH DOUBLE PANEL SLAM TAILGATE
with center latch and flat space for displaying company graphics

H. CAB PROTECTOR
welded on with fully punched window for visibility
**Knapliner applied on AKMT1*

I. (4) LED 3000 LUMEN WORK LIGHTS
installed (2 at front, 2 at rear) for low-light working conditions

J. HYDRAULIC OUTRIGGERS
out-and-down curb side and hydraulic down street side for crane stability during lifting operations

K. 55,000 FT-LB. CRANE
with 21' hydraulic reach, provided by a two-stage hydraulic extension (AKMT1, KMT1)

L. RECIPROCATING HYDRAULIC COMPRESSOR
up to 40 CFM (AKMT1, KMT1)

M. PLANETARY WINCH
provides a 60 ft. per minute single line speed

N. Knapliner
applied to cargo area floor, sides, compartment tops, bulkhead, bumper and tailgate for durability

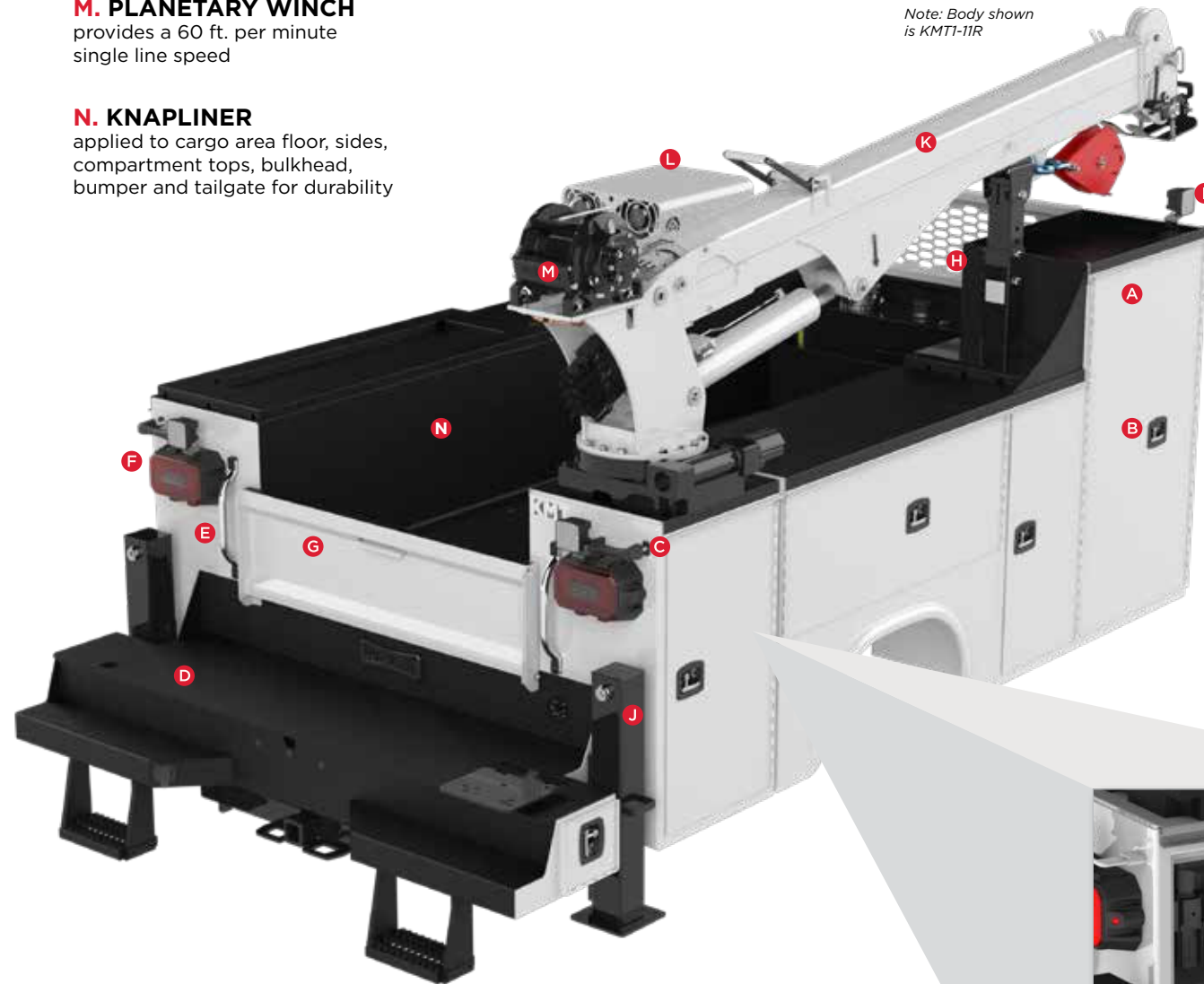

COMPARTMENT FEATURES



DOUBLE-SPRING OVER-CENTER RETAINER
on vertical compartment doors eliminate involuntary swing
**Aluminum models feature nitrogen strut door retainers*



NEOPRENE DOOR SEALS
protect compartments from the weather



ADJUSTABLE DIVIDER SHELVES
250-lb. capacity

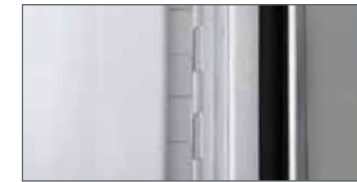

CONTINUOUS STAINLESS STEEL HINGES
are pry-proof and corrosion-resistant
**Aluminum models feature aluminum hinge with stainless steel rod*

FEATURES NOT SHOWN

SMALL PART STORAGE CONTAINERS
in horizontal compartment on street side

Knapheide's WATER-BASED UNDERCOAT
Bodies are fully protected with Knapheide's water-based undercoat

ELECTRODEPOSITION PRIME-PAINT SYSTEM
provides superior corrosion resistance

(6) D-RING CARGO TIE DOWNS
each D-ring provides a 2,000 lb. working load capacity

ALUMINUM MECHANIC 7-DRAWER SET
Extreme duty aluminum mechanic 7-drawer set on street side

MULTI-FUNCTION RADIO REMOTE CONTROL
provides convenient complete control of the crane

3/16" TREAD PLATE FLOOR
provides traction for safety

REINFORCED COMPARTMENT BOTTOMS AND END PANELS
Steel models feature 12-gauge panels. Aluminum models feature raised "sweep out" bottom panels

CRANE COMPARTMENT



50' X 1/2" COMPRESSOR HOSE REEL AND ROLLER FAIRLEAD
through curb side vertical compartment



POLYETHYLENE FORMED DRIP PAN WITH DRAIN HOSE
placed under the crane manages water intrusion through the crane pedestal



Knapheide CONTROLLER
10 output system features two displays for user interface points of control. CAN bus system with continuous working load of 115 amps features built-in overload current protection for system and operator safety

A. REINFORCED REAR VERTICAL CURB SIDE COMPARTMENT

eliminates flexing and twisting of side packs

B. DOUBLE PANELED DOORS

made of 20-gauge galvalume steel are reinforced with internal braces for durability

C. 3-POINT T-HANDLE LATCHES

ensure your compartment doors stay closed and are individually lockable

D. MASTER LOCKING SYSTEM

locks down all compartments on one side with one motion

E. KNAPLINER BUMPER

provides versatile work space on a flat surface

F. INTEGRATED LED S/T/T AND B/U, LED STROBES

with (8) selectable patterns and built-in reflectivity mounted to external rear light boxes made of UV-resistant ABS material

G. DOUBLE PANEL SLAM TAILGATE

with center latch and flat space for displaying company graphics

H. CAB PROTECTOR

welded on with fully punched window for visibility

**Knapliner applied on AKMS16*

I. (4) LED 3000 LUMEN WORK LIGHTS

installed for low-light working conditions

J. HEAVY DUTY ALUMINUM GRAB HANDLES

installed on both sides at rear of the body for easy cargo area access

K. (1) MANUAL OUTRIGGER

for crane stability during lifting operations

L. UP TO 16,000 FT-LB. CRANE

with 20' reach (AKMS16, KMS16)

UP TO 38,000 FT-LB. CRANE

with 21' reach (KMS30)

M. PLANETARY WINCH

provides a 15 ft. per minute single line speed

N. KNAPLINER

applied to cargo area floor, sides, compartment tops, bulkhead, bumper and tailgate for durability

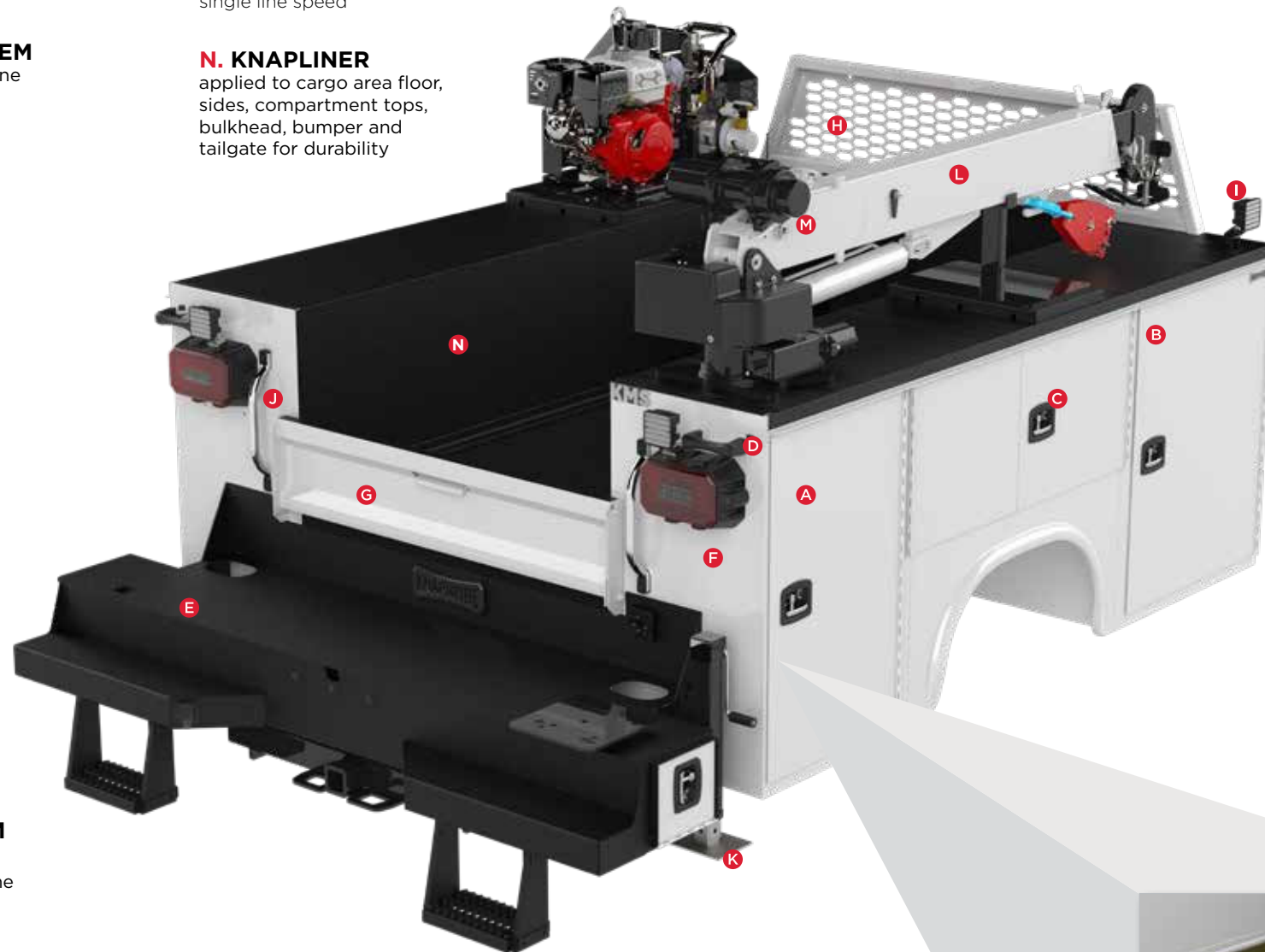

Note: Body shown is KMS16-09

COMPARTMENT FEATURES



DOUBLE-SPRING OVER-CENTER RETAINER

on vertical compartment doors eliminate involuntary swing

**Aluminum models feature nitrogen strut door retainers*



NEOPRENE DOOR SEALS

protect compartments from the weather



ADJUSTABLE DIVIDER SHELVES

250-lb. capacity



CONTINUOUS STAINLESS STEEL HINGES

are pry-proof and corrosion-resistant

**Aluminum models feature aluminum hinge with stainless steel rod*



POLYETHYLENE FORMED DRIP PAN WITH DRAIN HOSE

placed under the crane manages water intrusion through the crane pedestal

FEATURES NOT SHOWN

SMALL PART STORAGE CONTAINERS

in second horizontal compartment on street side

ALUMINUM MECHANIC 6-DRAWER SET

Extreme duty aluminum mechanic 6-drawer set on street side

D-RING CARGO TIE DOWNS

each D-ring provides a 2,000 lb. working load capacity (4 in 9' and 6 in 11')

KNAPHEIDE'S WATER-BASED UNDERCOAT

Bodies are fully protected with Knapheide's water-based undercoat

ELECTRODEPOSITION PRIME-PAINT SYSTEM

provides superior corrosion resistance

TORSION BOX SUBFRAME

Full-length

REINFORCED COMPARTMENT BOTTOMS AND END PANELS

Steel models feature 14-gauge panels. Aluminum models feature raised "sweep out" bottom panels

1/8" TREAD PLATE FLOOR

provides traction for safety

**10-gauge smooth steel flooring on AKMS16*



CRANE COMPARTMENT

KMS16 OFFERS A: CRANE REINFORCEMENT KIT

allows you to incorporate a crane up to 4,000 lb. capacity (16,000 ft-lb. max.) onto the rear curb side corner of your body as shown on KMS16.



REQUEST A QUOTE



Visit knapheide.com/quote and fill out the form to receive a quote and additional product information.

MODEL OPTIONS

AKMT1 & KMT1

MODEL	GVWR MIN./RANGE	BUMPER	BODY MATERIAL	BODY LENGTH	COMPARTMENT HEIGHT	COMPARTMENT DEPTH	CARGO AREA WIDTH	TOPS & BACKS	REAR HITCH
AKMT1-11	19,500-23,500	21" with step down	Aluminum	11'	44", 60" raised front option	22"	50"	11-gauge smooth aluminum	2.5" receiver tube below bumper
KMT1-11			Steel					1/8" smooth steel	

AKMS16, KMS16 & KMS30

MODEL	GVWR MIN./RANGE	MAXIMUM CRANE	BUMPER	BODY MATERIAL	BODY LENGTH	COMPARTMENT HEIGHT	COMPARTMENT DEPTH	CARGO AREA WIDTH	REAR HITCH
AKMS16-9	13,200-23,500	16,000 ft.-lb.	21" with outrigger tube	Aluminum	9'	44", 60" raised front option	22"	50"	2.5" receiver tube below bumper
KMS16-9				Steel					
AKMS16-11	13,200-23,500	16,000 ft.-lb.	21" with outrigger tube	Aluminum	11'	44", 60" raised front option	22"	50"	2.5" receiver tube below bumper
KMS16-11				Steel					
KMS30-11	14,000-23,500	38,000 ft.-lb.	12" with outrigger tube	Steel	11'	44", 60" raised front option	22"	50"	2.5" receiver tube below bumper

**AKMT/AKMS are installed packages only*

POPULAR OPTIONS



AUXILIARY LIGHTING



WELDER



LED COMPARTMENT LIGHTS



CARGO COVER



ADDITIONAL MECHANIC DRAWERS



STEEL MECHANIC DRAWERS



APU UNIT



LUBE SKID

KNAPHEIDE ALUMINUM MECHANICS TRUCKS ARE THE ANSWER TO YOUR PAYLOAD NEEDS

AKMS16-09 has weight reduction of approximately 530 lbs.*

AKMS16-11 has weight reduction of approximately 650 lbs.*

AKMT1-11 has weight reduction of approximately 1,000 lbs.*

**compared to Steel KMS & KMT models*

BODY WEIGHT SAVINGS = INCREASED PAYLOAD



COMMITMENT TO CORROSION RESISTANCE

Corrosion won't be a concern when you buy quality Knapheide products. To give you the best corrosion protection, we utilize a state-of-the-art, custom-designed, 12-step, SST cathodic electrodeposition finishing system, called "E-Coat."

It bonds prime paint to steel by an electroplating process to give you a superior coat of primer, resulting in better corrosion protection compared to spraying methods.

This system allows us to create products with the highest level of corrosion resistance available.



FOLLOW US
LIKE US
TAG US



**SIX YEAR, LIMITED
TIME WARRANTY ON
STEEL MECHANICS TRUCKS**

**TEN YEAR, LIMITED
TIME WARRANTY ON
ALUMINUM MECHANICS TRUCKS**



NO RUST THROUGH



**DOOR HINGES
WILL NOT FAIL OR
COME OFF BODY**



**LATCHES AND LOCK
CYLINDERS WILL NOT
FAIL TO OPERATE**



**SHELVES WILL NOT
BEND UNDER MAX.
LOAD OF 250 LBS.**

TO LEARN MORE VISIT
www.knapheide.com/warranty



NEVER SETTLE

If you are going to be a leader, it takes more than building a high-quality product. It means never being totally satisfied with that product, no matter how high quality it may be. It requires constant vigilance and a willingness to take a chance on something new. And it means exceeding expectations every time. As the industry changes, one thing never will—our commitment to making customers like you as productive and efficient as possible. We know you don't settle, and we don't either. That's why we want you never to settle for anything less than Knapheide on the back of your truck.

KNAPHEIDE. NEVER SETTLE.



The Knapheide Manufacturing Company
1848 Westphalia Strasse | Quincy, IL 62305
217-222-7131
www.knapheide.com